

SHELL & TUBE HEAT EXCHANGER

FOR EXCHANGE OIL AND WATER



BRAND 3Q ₂₅

OIL COOLER

MODEL : AP 99-05 C

- MATERIAL TUBE C = COPPER , F = COPPER LOW FINNED TUBE
- S = STAINLESS STEEL 304 , G = COPPER NICKEL LOW FINNED TUBE
- S1 = STAINLESS STEEL 316
- SL = STAINLESS STEEL 316L
- N30 = COPPER NICKEL 70/30
- TUBE LONE (CM)
- SHELL SIZE (INCH)
- A = REMOVABLE TUBE BUNDLE TYPE
- P = FIXED TUBE BUNDLE TYPE
- A = OIL COOLER , FA = MODIFIED TYPE
- R = OIL COOLER FOR SCREW COMPRESSOR , FR = MODIFIED TYPE

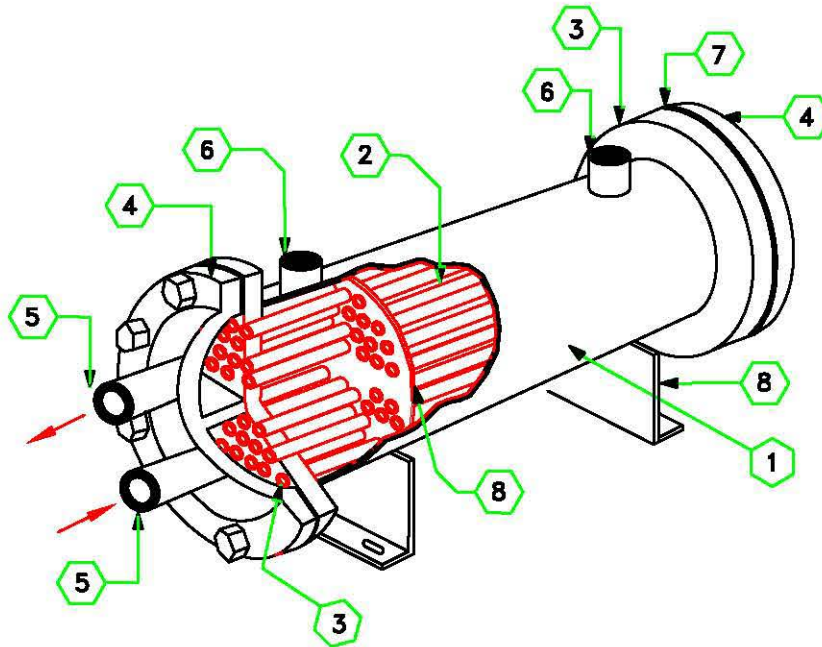

ITEM	DESCRIPTION	MATERIAL
1	SHELL	CARBON STEEL
2	TUBE	COPPER / STAINLESS 304 OR 316L
3	TUBE SHEET	CARBON STEEL
4	COVER	CARBON STEEL
5	WATER CONNECTION	CARBON STEEL
6	OIL CONNECTION	CARBON STEEL
7	GASKET	ISOPENE POLYMER COMPOUND
8	SUPPORT	CARBON STEEL

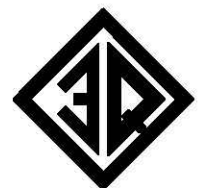

BRAND 3Q

OIL COOLER

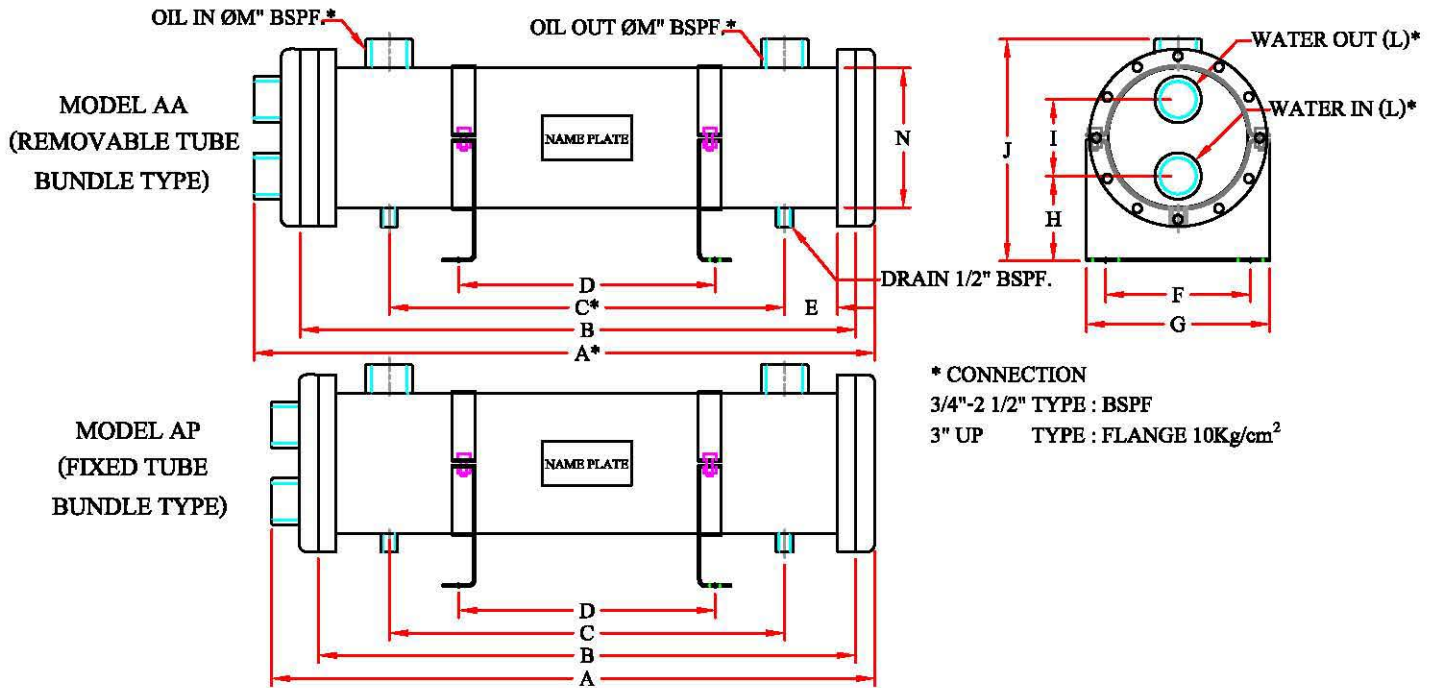

HEAT EXCHANGER MODEL AP (APCFIXED TUBG BUNDLE TYPE)

MODEL	DIMENSION millimetre										DIMENSION inch			Model AA DIMENSION (mm)		Weight (Kg)
	A	B	C	D	E	F	G	H	I	J	L	M	N	A*	C*	
AP 49-03	576	490	340	ADJUST TABLE	47	97	157	77	60	182	3/4"	3/4"	3 1/2"	-	-	30
AP 74-03	826	740	590		47	97	157	77	60	182	3/4"	3/4"	3 1/2"	-	-	34
AP 49-04	581	490	340	ADJUST TABLE	47	122	182	85	75	215	1"	1"	4 1/2"	-	-	55
AP 74-04	831	740	595		47	122	182	85	75	215	1"	1"	4 1/2"	-	-	61
AP 99-04	1081	990	840	ADJUST TABLE	57	149	209	103	87	256	1 1/4"	1 1/4"	5 1/2"	-	-	67
AP 49-05	586	490	320		57	149	209	103	87	256	1 1/4"	1 1/4"	5 1/2"	586	292	68
AP 74-05	836	740	570	ADJUST TABLE	67	176	236	113	98	284	1 1/2"	2"	6 1/2"	836	542	77
AP 99-05	1086	990	820		67	176	236	113	98	284	1 1/2"	2"	6 1/2"	1086	792	87
AP 119-05	1286	1190	1020	ADJUST TABLE	82	227	287	133	120	346	2"	2 1/2"	8 1/2"	1286	992	94
AP 74-06	840	740	550		82	227	287	133	120	346	2"	2 1/2"	8 1/2"	840	522	105
AP 99-06	1090	990	800	ADJUST TABLE	82	286	360	151	160	465	2 1/2"	Flange 3"	10 1/2"	1090	772	118
AP 119-06	1290	1190	1000		82	286	360	151	160	465	2 1/2"			10 1/2"	1290	972
AP 149-06	1590	1490	1300	ADJUST TABLE	92	286	360	168	196	526	Flange 3"	Flange 4"	12 1/2"	1590	1272	148
AP 74-08	845	740	520		92	286	360	168	196	526				12 1/2"	12 1/2"	845
AP 99-08	1095	990	770	ADJUST TABLE	1642	1490	1270	1100	1600	1142	Flange 3"	Flange 4"	12 1/2"	1095	742	182
AP 119-08	1295	1190	970		1642	1490	1270	1100	1600	1142				12 1/2"	12 1/2"	1295
AP 149-08	1595	1490	1270	ADJUST TABLE	2107	1990	1770	1600	2107	1742	Flange 3"	Flange 4"	12 1/2"	1595	1242	223
AP 199-08	2095	1990	1770		2107	1990	1770	1600	2107	1742				265		
AP 74-10	857	740	520	350	82	286	360	151	160	465	2 1/2"	Flange 3"	10 1/2"	857	492	245
AP 99-10	1107	990	770	600	82	286	360	151	160	465	2 1/2"			10 1/2"	1107	742
AP 119-10	1307	1190	970	800	92	286	360	168	196	526	Flange 3"	Flange 4"	12 1/2"	1307	942	303
AP 149-10	1607	1490	1270	1100	92	286	360	168	196	526				12 1/2"	12 1/2"	1607
AP 199-10	2107	1990	1770	1600	1142	990	750	600	1142	722	Flange 3"	Flange 4"	12 1/2"	2107	1742	406
AP 99-12	1142	990	750	600	1142	990	750	600	1142	722				376		
AP 119-12	1342	1190	950	700	1342	1190	950	700	1342	922	Flange 3"	Flange 4"	12 1/2"	1342	922	411
AP 149-12	1642	1490	1250	1000	1642	1490	1250	1000	1642	1222				465		
AP 199-12	2142	1990	1750	1500	2142	1990	1750	1500	2142	1722	554					



OIL COOLER

(PLAIN TUBE)

MODEL AA (Removable Bundle Tube Type) is available from shell 5"-12" ,AP (fix Bundled Tube Type)

Tube : PLAIN TUBE Ø1/2"

MODEL	HEAT KW	SHELLSIDE : HYDRAULIC OIL VG68						TUBE SIDE : WATER			HEAT SURF. ft ²	WEIGHT KG	WATER PASS
		100 BAR		150 BAR		200 BAR		FLOW L/MIN	TEMP IN/OUT °C	P.DROP mH2O			
		FLOW	P.DROP	FLOW	P.DROP	FLOW	P.DROP						
		L/MIN	BAR	L/MIN	BAR	L/MIN	BAR						
AP 49-03 X*	1.8	60*	0.3	30*	0.1	15*	0.03	27	30/31	0.3	2.2	30	2
AP 74-03	3.1	100*	0.7	50*	0.2	33*	0.1	30	30/31.5	0.4	4.3	34	2
AP 49-04	3.7	120*	0.4	60*	0.1	40*	0.07	35	30/31.5	0.7	5.4	55	4
AP 74-04	6.9	150**	0.7	90**	0.3	64*	0.2	50	30/32	1.6	8.6	61	4
AP 99-04	10.1	220**	1.3	132**	0.6	94*	0.4	58	30/32.5	2.5	10.8	67	4
AP 49-05	6.1	200*	0.5	100*	0.2	67*	0.1	59	30/31.5	0.8	9.7	68	4
AP 74-05	12	250**	0.7	150**	0.4	107*	0.3	83	30/32	1.8	11.8	77	4
AP 99-05	15	320**	1.1	192**	0.5	137*	0.4	85	30/33	2.1	16.1	87	4
AP 119-05	20	400**	1.5	240**	0.6	170**	0.4	89	30/33	2.6	20.4	94	4
AP 74-06	17	370**	0.9	222**	0.5	159**	0.3	123	30/32	1.8	18.3	105	4
AP 99-06	24	510**	1.5	306**	0.7	219**	0.5	136	30/32.5	2.8	24.7	118	4
AP 119-06	30	660**	2.0	396**	0.9	283**	0.6	125	30/33.5	2.4	30.1	128	4
AP 149-06	39	840**	2.5	504**	1.1	360**	0.7	140	30/34	3.3	37.7	148	4
AP 74-08	32	700**	1.7	420**	0.8	300**	0.5	232	30/32	2.1	32.3	161	4
AP 99-08	44	950**	2.0	570**	0.9	407**	0.6	252	30/32.5	2.8	43.0	182	4
AP 119-08	55	1200**	2.6	720**	1.1	514**	0.7	240	30/33.5	2.6	52.7	199	4
AP 149-08	74	1200	2.8	800	1.5	600	0.9	266	30/34	3.8	65.6	223	4
AP 199-08-2	98	1600	3.7	1067	2.0	800	1.2	405	30/33.5	2.0	32.3	265	2
AP 199-08-4	98	1600	3.7	1067	2.0	800	1.2	405	30/33.5	2.0	32.3	265	4
AP 74-10	55	900	1.3	600	0.8	514**	0.6	398	30/32	2.2	54.9	245	4
AP 99-10	80	1300	1.7	867	0.9	743**	0.8	384	30/33	2.3	74.2	277	4
AP 119-10	98	1600	2.9	1400	1.3	1050	0.9	405	30/33.5	2.9	90.4	303	4
AP 149-10	117	1900	3.2	1260	1.6	950	1.2	421	30/33	1.4	114.0	342	4
AP 199-10-2	169	2200***	4.3	1571	2.6	1222***	1.7	696	30/33.5	2.3	152.8	406	2
AP 199-10-4	169	2200***	4.3	1571	2.6	1222***	1.7	696	30/33.5	2.3	152.8	406	4
AP 99-12	104	1700	2.1	1133	1.2	850	0.8	602	30/32.5	2.8	109.7	376	4
AP 119-12	129	2100	2.4	1400	1.3	1050	0.9	531	30/33.5	2.4	133.4	411	4
AP 149-12	166	2700	4.2	1800	2.3	1350	1.5	646	30/32.5	1.8	168.9	465	4
AP 199-12-2	223	2900***	3.7	2070***	2.2	1611***	1.5	1070	30/33	2.4	228.1	554	2
AP 199-12-4	223	2900***	3.7	2070***	2.2	1611***	1.5	1070	30/33	2.4	228.1	554	4

REMARK : - TUBE SIDE : WATER TEMP IN = 30 °C

- SHELL SIDE :

HYDRAULIC OIL VG68				
PRESSURE BAR	TEMP IN/OUT (°C)			
	IN/OUT	IN/OUT	IN/OUT	IN/OUT
100	52/50	*51/50	**51.5/50	***52.5/50
150	53/50	*52/50	**52.5/50	***53.5/50
200	54/50	*53/50	**53.5/50	***54.5/50

-MODEL AP 49-X*;

- X* = TUBE MATERIAL
- C = COPPER
- S = STAINLESS STEEL 304
- S1 = STAINLESS STEEL 316
- SL = STAINLESS STEEL 316L
- N30 = COPPER NICKEL 70/30
- F = COPPER LOW FINNED TUBE
- G = COPPER NICKEL LOW FINNED TUBE



BRAND 3Q

OIL COOLER

(LOW FINNED TUBE)

MODEL AA (Removable Bundle Tube Type) is available from shell 5"-12" ,AP (fix Bundled Tube Type)

Tube : COPPER LOW FINNED TUBE Ø1/2" 26 Fin/inch

MODEL	HEAT KW	SHELL SIDE : HYDRAULIC OIL VG68						TUBE SIDE : WATER			HEAT SURF. ft ²	WEIGHT KG	WATER PASS
		100 BAR		150 BAR		200 BAR		FLOW L/MIN	TEMP °C	P.DROP mH2O			
		FLOW	P.DROP	FLOW	P.DROP	FLOW	P.DROP						
		L/MIN	BAR	L/MIN	BAR	L/MIN	BAR						
AP 49-03 X*	2.8	60*	0.3	36*	0.1	26*	0.1	40	30/31	1.1	6.5	30	2
AP 74-03	5.1	110*	0.7	73*	0.3	55*	0.2	37	30/32	1.1	10.8	34	2
AP 49-04	5.1	110*	0.4	66*	0.2	47*	0.1	49	30/31.5	0.6	12.9	55	4
AP 74-04	9.2	150	0.7	100	0.4	75	0.2	66	30/32	1.2	20.4	61	2
AP 99-04	13.5	220	1.3	146	0.7	110	0.4	78	30/32.5	1.9	26.9	67	2
AP 49-05	7.8	170*	0.5	100*	0.2	73*	0.1	75	30/31.5	0.6	23.7	68	4
AP 74-05	15	240	0.6	160	0.4	137*	0.4	106	30/32	1.3	30.1	77	2
AP 99-05	18	300	1.0	200	0.6	150	0.4	133	30/32	2.2	40.9	87	2
AP 119-05	25	400	1.5	266	1.0	200	0.5	142	30/32.5	2.7	20.4	94	2
AP 74-06	23	370	1.0	246	0.6	185	0.3	164	30/32	1.4	45.2	105	2
AP 99-06	31	510	1.6	340	0.7	255	0.6	180	30/32.5	1.9	61.3	118	2
AP 119-06	41	660	2.1	440	1.1	330	0.7	195	30/33	2.4	74.2	128	2
AP 149-06	52	850	2.7	570	1.4	430	0.9	215	30/33.5	3.3	93.6	148	2
AP 74-08	43	700	1.9	433	0.9	350	0.6	289	30/32	1.4	78.5	161	2
AP 99-08	58	950	2.2	712	1.1	475	0.8	337	30/32.5	2.2	107.6	182	2
AP 119-08	74	1200	2.8	800	1.5	600	0.9	354	30/33	2.6	130.2	199	2
AP 149-08	101	1500	4.5	1000	2.7	750	1.7	365	30/34	3.1	163.5	223	2
AP 199-08	138	1500**	3.2	1050**	2.0	900**	1.5	398	30/35	4.4	218.4	265	2
AP 74-10	68	1100	2.0	730	1.1	550	0.7	487	30/32	1.5	135.6	245	2
AP 99-10	98	1600	2.7	1083	1.4	810	0.9	480	30/33	1.7	184.0	277	2
AP 119-10	120	1300**	2.3	975**	1.5	780**	1.1	493	30/33.5	2.0	223.8	303	2
AP 149-10	166	1800**	3.2	1350**	2.0	1080**	1.4	598	30/34	3.1	281.9	342	2
AP 199-10	212	2300**	3.8	1720**	2.4	1380**	1.6	611	30/35	3.9	378.7	406	2
AP 99-12	138	2000	3.0	1340	1.9	1000	1.2	797	30/32.5	2.2	273.3	376	2
AP 119-12	166	2800	4.3	1867	2.2	1400	1.4	708	30/33.5	1.9	332.4	411	2
AP 149-12	239	2600**	4.4	1950**	2.7	1560**	1.9	863	30/34	3.1	420.7	465	2
AP 199-12	324	-	-	2800**	3.9	2160**	2.5	957	30/35	4.4	567.0	554	2

REMARK : - TUBE SIDE : WATER TEMP IN = 30 °C

- SHELL SIDE :

HYDRAULIC OIL VG68			
PRESSURE BAR	TEMP IN/OUT (°C)		
	IN/OUT	IN/OUT	IN/OUT
100	52/50	*51.5/50	**53/50
150	53/50	*52.5/50	**54/50
200	54/50	*53.5/50	**55/50

- MODEL AP 49-X*;
- X* = TUPE MATERIAL
- C = COPPER
- S = STAINLESS STEEL 304
- S1 = STAINLESS STEEL 316
- SL = STAINLESS STEEL 316L
- N30 = COPPER NICKEL 70/30
- F = COPPER LOW FINNED TUBE
- G = COPPER NICKEL LOW FINNED TUBE



BRAND 3Q

OIL COOLER FOR COMPRESSOR (REFRIGERANT)

MODEL : RP 99-05 C

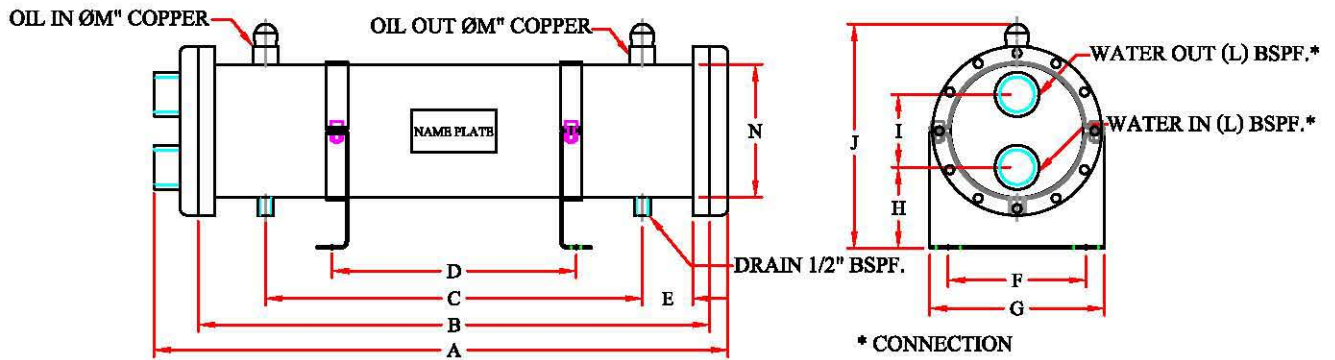
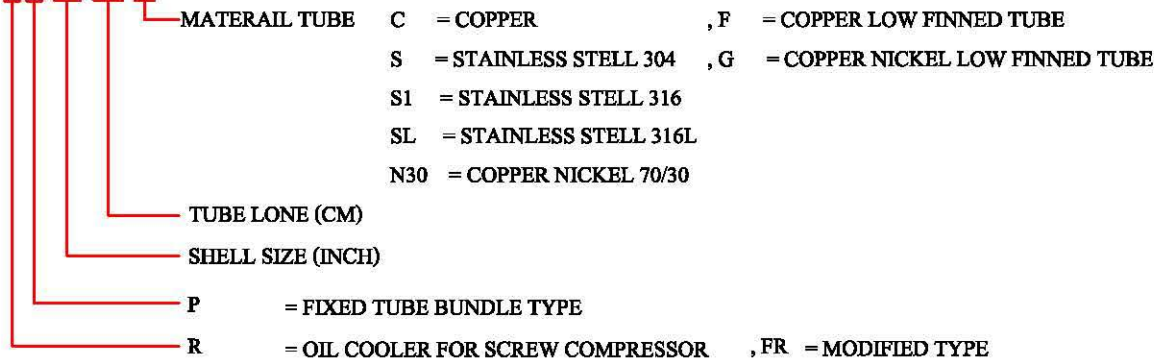

* CONNECTION
 3/4"-2 1/2" TYPE : BSPF
 3" UP TYPE : FLANGE 10Kg/cm²

OIL COOLER FOR COMPRESSOR (REFRIGERANT)

MODEL RP (FIXED TUBE BUNDLE TYPE)

MODEL	DIMENSION millimetre										DIMENSION inch			Heat Transfer (ft ²)	Weight (Kg)
	A	B	C	D	E	F	G	H	I	J	L	M	N		
RP 59-04	681	590	440	ADJUST TABLE	47	122	182	85	75	209	1"	3/4"	4 1/2"	15.7	57
RP 74-04	831	740	590											19.9	61
RP 99-04	1081	990	840											26.8	67
RP 59-05	686	590	430	ADJUST TABLE	52	149	209	103	87	274	1 1/4"	7/8"	5 1/2"	24.1	70
RP 74-05	836	740	580											30.4	77
RP 99-05	1086	990	830											41.1	87
RP 119-05	1286	1190	1030	ADJUST TABLE	52	176	236	113	98	306	1 1/2"	1 1/8"	6 1/2"	49.6	94
RP 74-06	846	740	580											45.3	105
RP 99-06	1090	990	830											61.3	118
RP 119-06	1290	1190	1030	ADJUST TABLE	67	227	287	133	120	368	2"	1 3/8"	8 1/2"	74.1	128
RP 74-08	845	740	550											78.0	161
RP 99-08	1095	990	800											107.2	182
RP 119-08	1295	1190	1000	ADJUST TABLE	67	286	360	151	160	446	2 1/2"	1 5/8"	10 1/2"	129.7	199
RP 149-08	1595	1490	1300											163.6	223
RP 74-10	857	740	550											350	134.9
RP 99-10	1107	990	800	600	ADJUST TABLE	67	286	360	151	160	452	2 1/2"	10 1/2"	184.0	277
RP 119-10	1307	1190	1000	700										223.2	303
RP 149-10	1607	1490	1300	1000										282.0	342

